

PHASE CONTROL

Installation Instructions #1825

This bulletin describes the installation of a Phase Control on a Plug-in Control Plate. The Phase Control can also be installed on Control Plates without the Plug-in modification manufactured after 1980 (the plates must have the switch mounting holes for either the Carbon Switch or the Flat blade Micro switch). Control Plates without the Plug-in modification can be upgraded.

1. Remove the Plug-in Control Plate from the Platter System by grasping it with both hands and pulling straight up. (**NOTE:** If you do not have Plug-in Control Plates, use the Control Plate removal instructions from the Operations Manual which came with your Platter System.)
2. Disconnect the red and blue wires from the switch currently on the Control Plate and remove the switch and all switch mounting hardware from the Control Plate.

3. Relocate the feed pulley to the hole designated for use with the Phase Control (See Fig. 1). This hole is not present on Control Plates manufactured before 1991. The Phase Control will still function if the feed pulley is not moved, however best operating results will be obtained if it is moved. Part number 1843 (Drill Template Kit) is available if you need to add the hole.

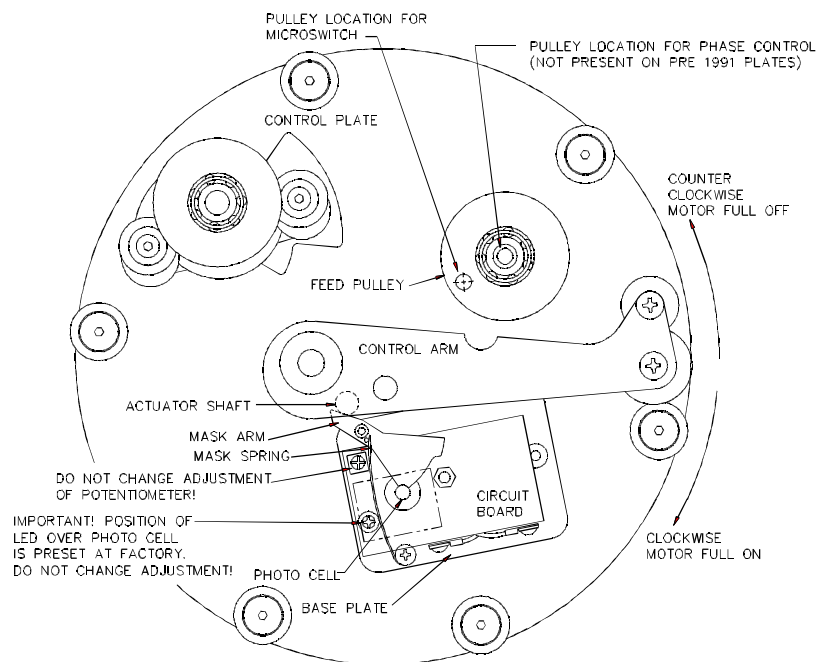

Figure 1

4. The actuator shaft (See Fig. 1) on control plates manufactured before 1991 is made of plastic. Using a steel shaft here will improve the performance of the Phase Control. Order part number 1265 (Shaft), and part number 1069 (Screw) to replace the plastic shaft.

Phase Control Installation (continued)

5. Remove the screw and washer from the Phase Control cover. Position the Mask Arm in the center of its vertical slot and remove the cover. Position the uncovered Phase Control on the Control Plate and route the red and blue wires between the Base Plate and the Circuit Board, one on either side of the center standoff, and connect the wires to the switch (See Fig. 2). **The Phase Control will not function correctly if the wires are reversed.**
6. Use the two mounting screws provided to attach the Phase Control to the Control Plate. Be sure the Mask Arm is located correctly in relation to the Actuator Shaft (See Fig. 1). The flat head screw goes in the mounting hole closest to the center standoffs. The truss head screw goes in the mounting hole closest to the edge of the Phase Control (See Fig. 2).
7. The Phase Control needs to be adjusted before reinstalling the Control Plate on the Platter System. (See Product Information Bulletin 1802, Phase Control Adjustment.)

NOTE: The potentiometer inside the Phase Control has been preset at the factory and should not be altered. The position of the LED over the Photo Cell is also preset at the factory and should not be altered. Only position adjustments should be required to make the Phase Control function properly.

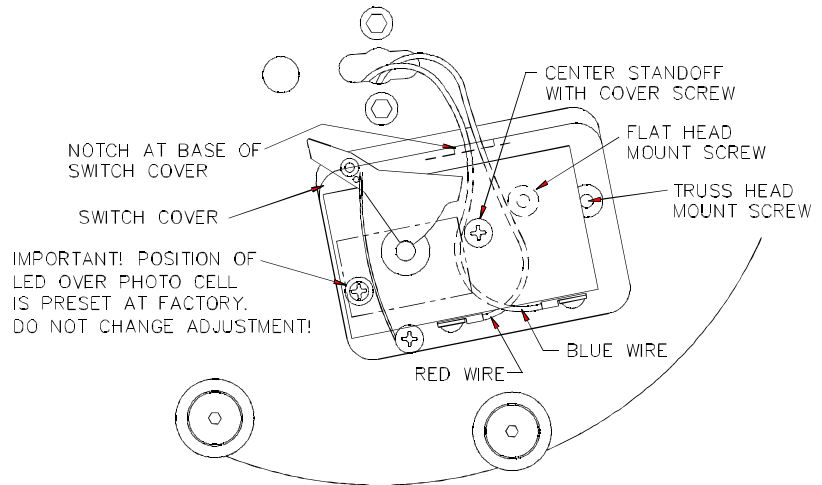

Figure 2