

# ***New Feature:***

## **Drive Motor Timing Adjustments**

### **PIB #4691**

#### **Adjusting motor timing by bypassing diode.**

The operating speed can also be increased by bypassing the motor diode. To bypass the diode simply remove the motor cover, disconnect the diode leads and connect the motor leads together as shown below. Tuck the diode wires out of the way and leave disconnected. Make sure the wiring does not contact moving parts. Reinstall the motor cover.

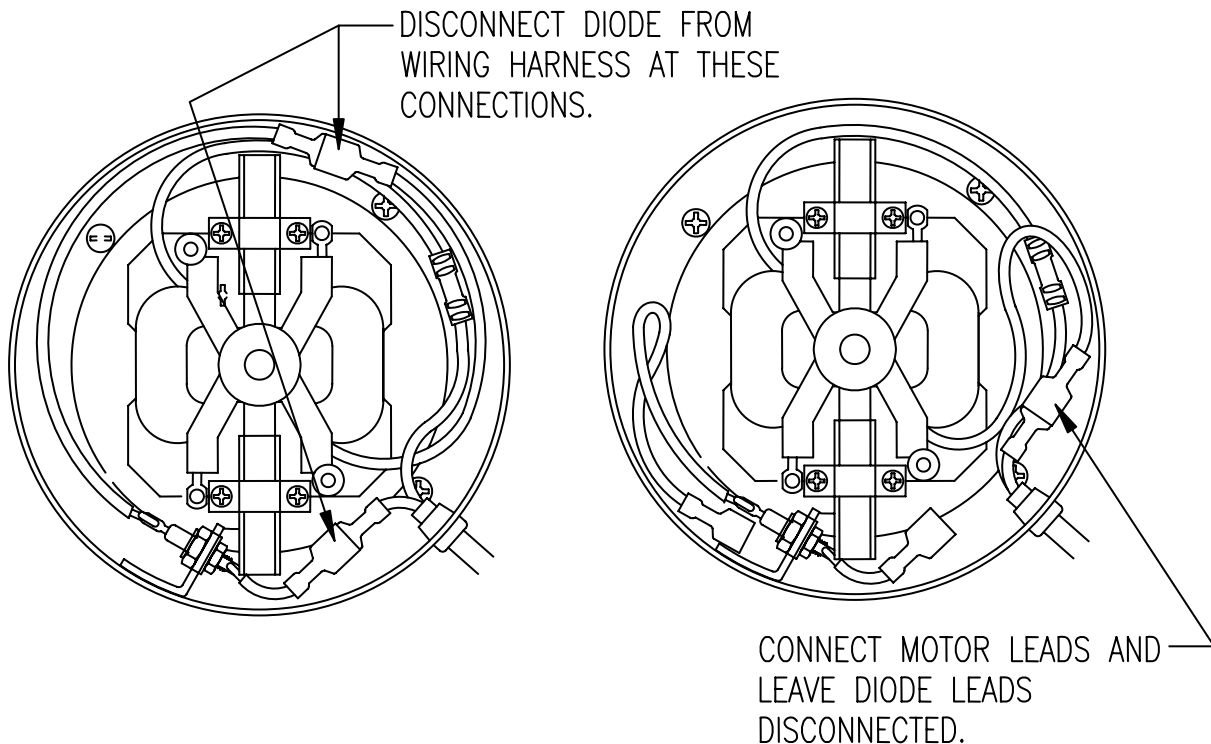

#### **Adjusting timing using Drive Hub.**

All replacement motors for platter systems manufactured with 1/2" diameter drive hubs are shipped with 1/2" drive hubs installed. All replacement motors for platter systems manufactured with 3/8" diameter drive hubs are shipped with 3/8" drive hubs installed. We are now including both diameter drive hubs with each replacement motor to aid in

platter timing.

Due to motor manufacturing tolerances, the motors that are manufactured today may run slower at the same voltage as motors manufactured 15 years ago. To match the speed of motors manufactured today with the speed of older motors in use, it may be necessary to replace the 3/8" diameter drive hub with a 1/2" diameter drive hub. If, during normal timing procedure, the replacement motor is slower than the existing drive motors we recommend replacing the 3/8" diameter drive hub with the 1/2" diameter drive hub. This will increase disk speed at the same voltage setting.

If the platter system has 1/2" diameter drive hubs on all drive motors and the replacement motor with a 1/2" diameter drive hub runs slow, the original motors will need to have 3/8" diameter drive hubs installed. This will decrease disk speed at the same voltage setting.

Additional drive hubs required can be ordered from the chart below.

To remove the drive hub from the motor insert an 1/8" allen wrench in the end of the drive hub as shown until it engages the motor shaft. Grasp the drive hub with pliers or vise grips as close to the motor as possible. Turn the drive hub counter-clockwise.

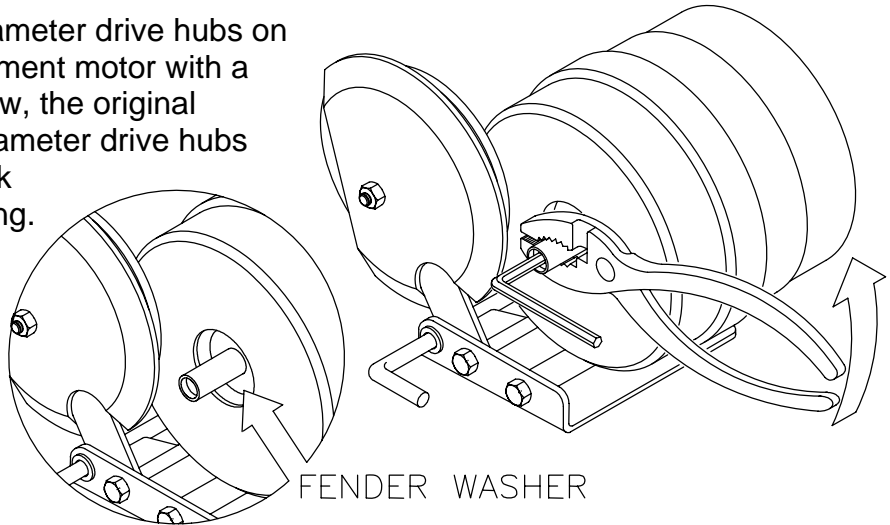

To install the new drive hub, reverse the procedure. Make sure the existing fender washer is installed under the hub. Remove any nicks on the drive hub where the drive tires contact the hub using a file or emery cloth.

**IMPORTANT: Running the motor without the hub and fender washer installed will result in motor damage!**

### Drive Hub Replacement Chart

1/2" Short (1 1/4" long)	Part No. 2931
1/2" Long (2" long)	Part No. 1190
3/8" Short (1 1/4" long)	Part No. 1630
3/8" Long (2" long)	Part No. 1747