

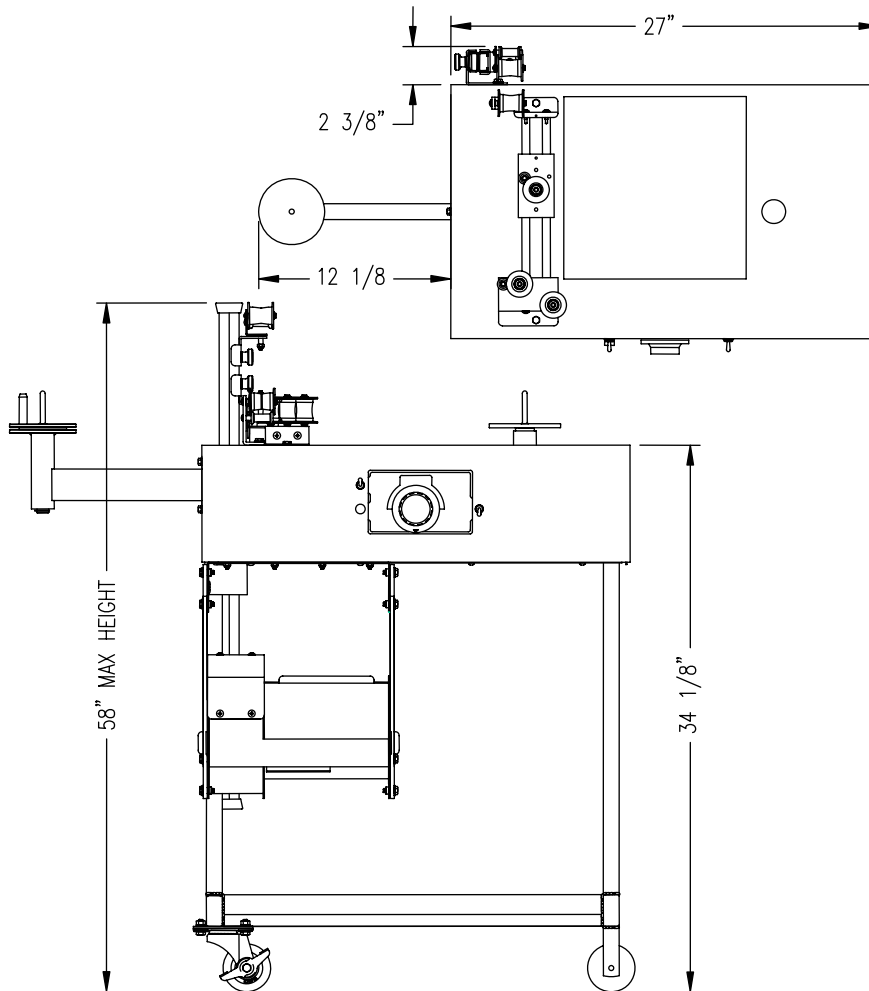
# DELUXE TABLE 35mm Operation Manual #7118

## 110VAC and 220VAC OPERATION

Record Platter System Identification Numbers Here:

Model # \_\_\_\_\_ Serial # \_\_\_\_\_

Safety Instructions	2-4
Make-up Table Application	5
Program Make-up	5-7
Program Break-down	7-8
Splicing Station Operation	8
Trouble Shooting	8-9
Maintenance	9
Threading Diagrams	10-11
Wire Schematics	12-13



# IMPORTANT SAFETY INSTRUCTIONS

1. Read and understand all instructions before using.
2. Do not operate appliance with a damaged cord or if the appliance has been dropped or damaged-until it has been examined by a qualified serviceman.
3. Position the cord so that it will not be tripped over, pulled or contact hot surfaces.
4. If an extension cord is necessary, a cord with a current rating at least equal to that of the appliance should be used. Cords rated for less amperage than the appliance may overheat.
5. Always unplug appliance from electrical outlet before cleaning and servicing and when not in use. Never yank cord to pull plug from outlet. Grasp plug and pull to disconnect.
6. To reduce the risk of electric shock, do not use this product near water or other liquids.
7. To reduce the risk of electric shock, do not disassemble this appliance. Refer all work to a qualified serviceman when service or repair work is required. Incorrect re-assembly can cause electric shock when the appliance is used subsequently.
8. The use of an accessory attachment not recommended by the manufacturer may cause a risk of fire, electric shock or injury to persons.
9. Connect this appliance to a grounded outlet.
10. Disconnect this unit from its source of supply before replacing the lamps.

The symbol shown here is the safety-alert symbol. When this symbol appears in this manual or on the product, be alert for the potential for personal injury.

Always follow recommended precautions and safe operating procedures.



Whenever you see the safety-alert symbol a signal word is used to identify the most serious hazards.

The word CAUTION warns of possible injury. The Caution signal word appears in black text on yellow on the decal.



The word WARNING warns of serious injury or possible death! The word Warning appears in black text on orange on the decal.



The word DANGER warns of imminent death or critical injury! The word Danger appears in white text on red on the decal.



The following decals are placed on the machine for your safety and the safety of others who may operate the machine. Always maintain the safety decals in good readable condition. If any of these decals are missing, damaged or unreadable, replace immediately.



Decal, Fuse Replacement  
Order part number 3788.  
Located on front of table.



Decal, Disconnect Power Supply  
Order part number 3790  
Located on front of table.



Decal, Hazardous Voltage  
Order part number 7330  
Located near the power supply inlet.

**SAVE THESE INSTRUCTIONS!**

## GROUNDING INSTRUCTIONS



### **WARNING**

**THIS PRODUCT MUST BE GROUNDED WHILE IN USE TO PROTECT THE OPERATOR FROM ELECTRIC SHOCK!**

In the event of a malfunction, grounding provides the path of least resistance for electric current to reduce the risk of electric shock. This product is equipped with an electrical cord that has a grounding conductor and a grounding plug. The plug **MUST** be plugged into a matching electrical receptacle that is properly installed and grounded in accordance with **ALL** local codes and ordinances.



### **DANGER**

**DO NOT MODIFY THE PLUG PROVIDED.**

If it will not fit the electrical receptacle, have the proper receptacle installed by a qualified electrician. Improper electrical connection of the equipment-grounding conductor can result in risk of electric shock. The conductor with green insulation (with or without yellow stripes) is the equipment-grounding conductor.

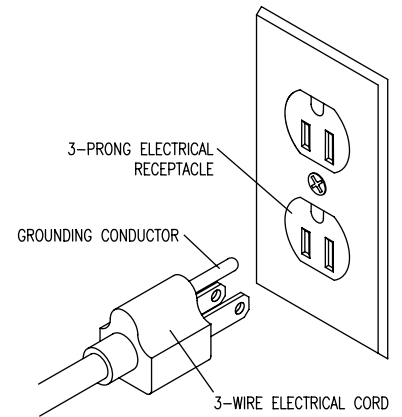
**DO NOT** connect the equipment-grounding conductor to a live terminal if repair or replacement of the electric cord or plug is necessary.

Check with a qualified electrician or service personnel if you do not completely understand the grounding instructions, or if you are not sure the equipment is properly grounded.

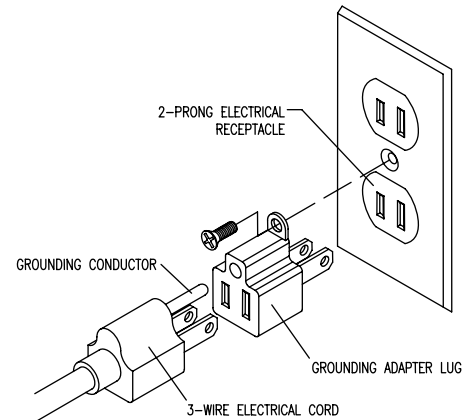
**USE ONLY A 3-WIRE EXTENSION CORD THAT HAS A 3-PRONG GROUNDING PLUG AND A 3-POLE RECEPTACLE THAT ACCEPTS THE POWER SUPPLY CORD'S PLUG. REPLACE A DAMAGED OR WORN CORD IMMEDIATELY.**

This product is intended for use on a circuit that has an electrical receptacle with a grounding conductor as shown in Figure 1. If a properly grounded electrical receptacle is not available, an adapter (see Figure 2) can be used to **temporarily** connect this plug to a 2-contact ungrounded receptacle. The adapter has a rigid lug extending from it that **MUST** be connected to a permanent earth ground, such as a properly grounded receptacle box.

**THIS ADAPTER IS PROHIBITED IN CANADA.**



**Figure 1**



**Figure 2**



### **WARNING**

**In all cases, make certain the electrical receptacle is properly grounded. If you are not sure, have a certified electrician check the electrical receptacle.**

## MAKE-UP TABLE APPLICATION

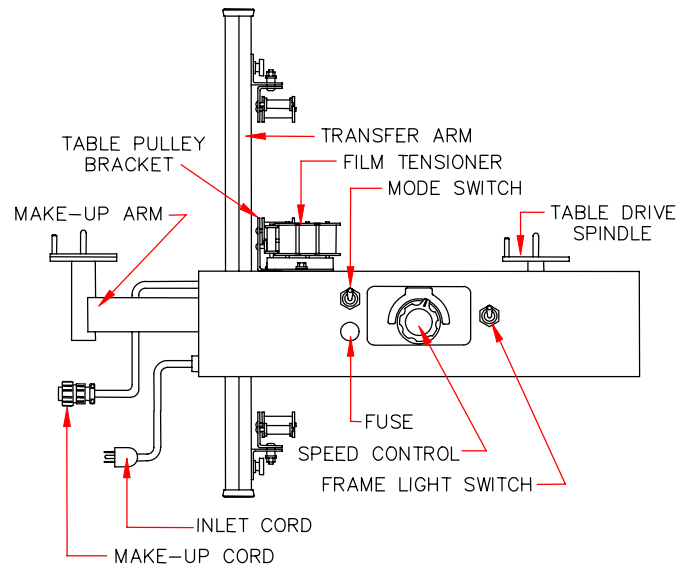
The Table 35mm is used to “make-up” and “break-down” the Auto Programming Platter System.

Feature films arrive at the theater on numerous shipping reels and, after exhibition, they must leave the theater on the same shipping reels. The term “make-up” refers to the process of sequentially loading the numerous shipping reels onto the platter system. During the “make-up” process, “leaders” and “trailers” are removed and the “tail” of one shipping reel is spliced to the “head” of the next reel in the sequence.

The term “break-down” describes the reverse process which occurs after the last showing of the film and prior to shipping of the shipping reels. During the “break-down” process, the “leaders” and “trailers” are reinserted at the splices between the shipping reels.

### PROGRAM MAKE-UP

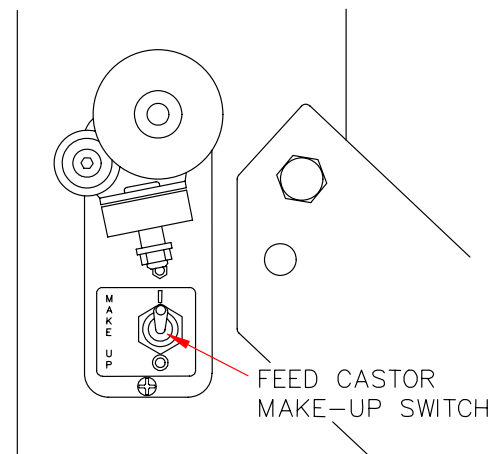
At this time you have the platter set up, the disks installed and you are ready to make-up the program. There are several ways to put film on a platter; sound side up, sound side down, emulsion in, emulsion out, etc. Since the operator has his or her own style, we will attempt to explain how the platter feeds and rewinds film and leave the film orientation to the operator. However, there is one rule; the beginning of one reel must match the end of the preceding reel. Sound track, emulsion and proper framing are of utmost importance for a smooth running program.



**Figure 3**

In PROGRAM MAKE-UP, you transfer film from the make-up table to the platter. The make-up platter is powered from the table and pulls film from the table make-up spindle.

1. Position the table with the transfer arm next to the platter system so that the swivel rollers on the transfer arm will castor freely toward the center of the platter.
2. Set the TABLE MODE SWITCH to OFF and turn the speed control knob all the way counterclockwise.

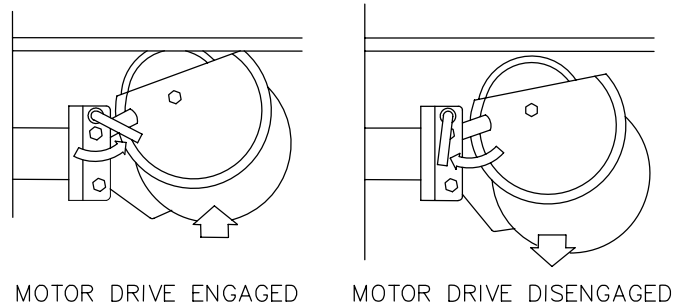


**Figure 4**

Program Make-up (continued)

3. Plug the table power cord into a 110/120 volt AC 50-60 Hz or 220 volt AC 50-60 Hz power outlet as required. On 120vac models, pull enough of the table make-up cord from the end of the table to reach the electrical panel on the VARIAC and plug it into the four pin receptacle labeled TABLE PORT. CE (220 vac) models use a fixed length cord. Set the TABLE MODE SWITCH to MAKE-UP.

4. Select an appropriate platter to make-up the first program. Set the FEED CASTOR MAKE-UP SWITCH to "I" (ON) (see Figure 4) and engage the DRIVE MOTOR (See Figure 5).

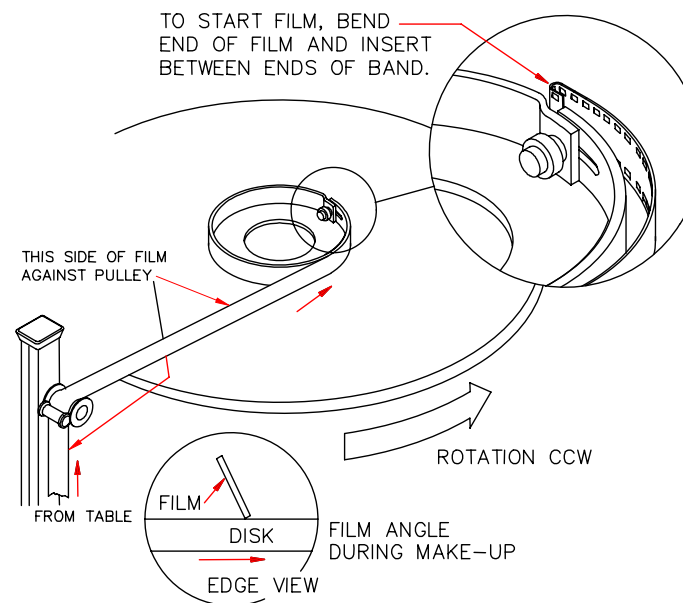


**Figure 5**

5. Place a center ring onto the make-up platter with the pins inserted into the holes provided. Make sure the center ring is locked in the extended position.

6. Add necessary leader to the first reel. Place the reel on the make-up arm spindle, thread the leader through the table and to the make-up platter. Table threading diagrams are shown on pages 10 and 11.

7. Connect the film to the center ring and rotate the disk counterclockwise by hand for at least two revolutions to insure proper film path alignment. Adjust the height of the swivel rollers on the make-up table transfer arm to assure clearance of 1/8" to 1/4" between the film and the outer edge of the disk.



**Figure 6**

8. Slowly turn the table speed control clockwise. Check the film path for proper pulley alignment. The make-up platter will pull the film from the table make-up arm. Near the end of the reel, reduce the speed of the make-up disk GRADUALLY. You want to stop the reel before the trailer starts to leave the table, allowing splices to be made on the table top with the aid of the framing light in the splicing station.

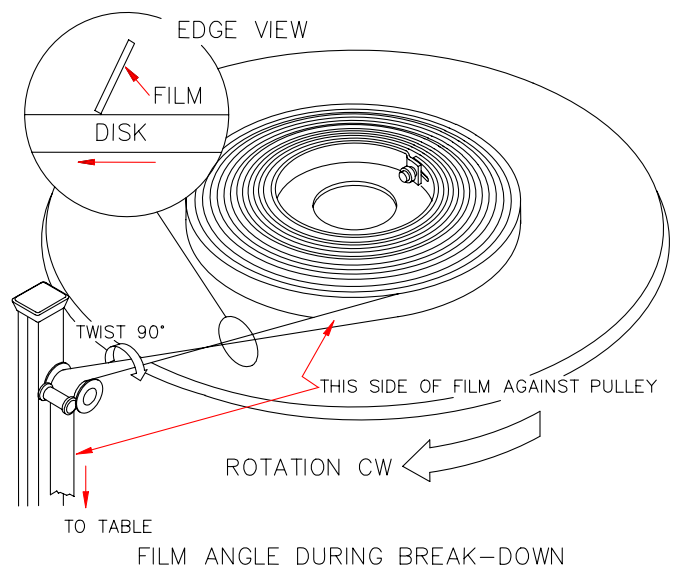
Program Make-up (continued)

9. Remove the trailer from the first reel and the leader from the second reel. Check the emulsion, sound track and framing. Make the splice and repeat steps 8 and 9 for each remaining reel.
10. Set the table mode switch to OFF. Set the FEED CASTOR MAKE-UP SWITCH to "O" (OFF). The table may remain plugged into the platter system without effecting other platter functions. PROGRAM MAKE-UP is now complete.

## **PROGRAM BREAK-DOWN**

PROGRAM BREAK-DOWN is essentially the reverse of PROGRAM MAKE-UP. Film is transferred, one shipping reel length at a time, from the platter to the table TAILS first. The MAKE-UP TABLE drive spindle holds the shipping reels and provides the power to wind the film on the shipping reel. The platter holding the film must be free-wheeling during this operation (DRIVE MOTOR disengaged).

1. Position the table with the transfer arm next to the platter system so that the swivel rollers on the transfer arm will castor freely toward the outside edge of the platter.
2. Set the TABLE MODE SWITCH to "Off" and turn the speed control knob all the way counterclockwise.
3. Plug the table power cord into a 110/120 volt AC 50-60 Hz power outlet or 220 volt AC 50-60 Hz power outlet as required. Set the TABLE MODE SWITCH to REWIND.



**Figure 7**

4. Place a trailer on the TAIL of the film and place an empty shipping reel on the table drive spindle. Thread the trailer through the table to the shipping reel. Table threading diagrams are on pages 10 and 11.
5. Connect the film to the shipping reel and rotate the reel clockwise by hand for at least two revolutions to insure proper film path alignment. Adjust the height of the swivel rollers on the make-up table transfer arm to assure clearance of 1/8" to 1/4" between the film and the outer edge of the disk.

6. Disengage the drive motor on the platter now.



## **CAUTION**

**Failure to disengage the platter drive motor will overload the table drive motor and likely cause motor damage and/or film damage.**

7. Slowly turn the table speed control clockwise. Check the film path for proper pulley alignment. The shipping reel will pull the film from the platter. Near the end of the reel length, reduce the speed of the make-up disk GRADUALLY. You want to stop the reel before the splice (made at PROGRAM MAKE-UP) goes on the shipping reel.
8. Cut the splice and add the necessary leader to the film on the shipping reel. That reel is now complete, ready to pack and ship.
9. Repeat steps 4, 5, 7 and 8 until all the film is on the shipping reels. PROGRAM BREAK-DOWN is now complete.

## **SPLICING STATION OPERATION**

The splicing station allows quick access to a framing light and splicer by simply swinging the station toward the front and upward. As the station is raised, lock pins will be depressed by ramps on the front arms and pins will extend into the arm slots. Pulling forward on the release handle located below the storage compartment will retract the pins and allow the station to be lowered. Do not allow the station to drop.



## **CAUTION**

**DO NOT move the make-up table with the splicing station in the working (raised) position.**

## **TROUBLE SHOOTING**

1. If the platter does not turn for PROGRAM MAKE-UP:
  - a) Make sure the FEED CASTOR MAKE-UP is set to "I" (ON).
  - b) Make sure the DRIVE MOTOR is ENGAGED.
  - c) Make sure the TABLE MAKE-UP CORD is correctly plugged into the TABLE PORT (on the VARIAC).
  - d) Make sure the TABLE MODE SWITCH is in the MAKE-UP position.
  - e) Check the MAKE-UP TABLE fuse.

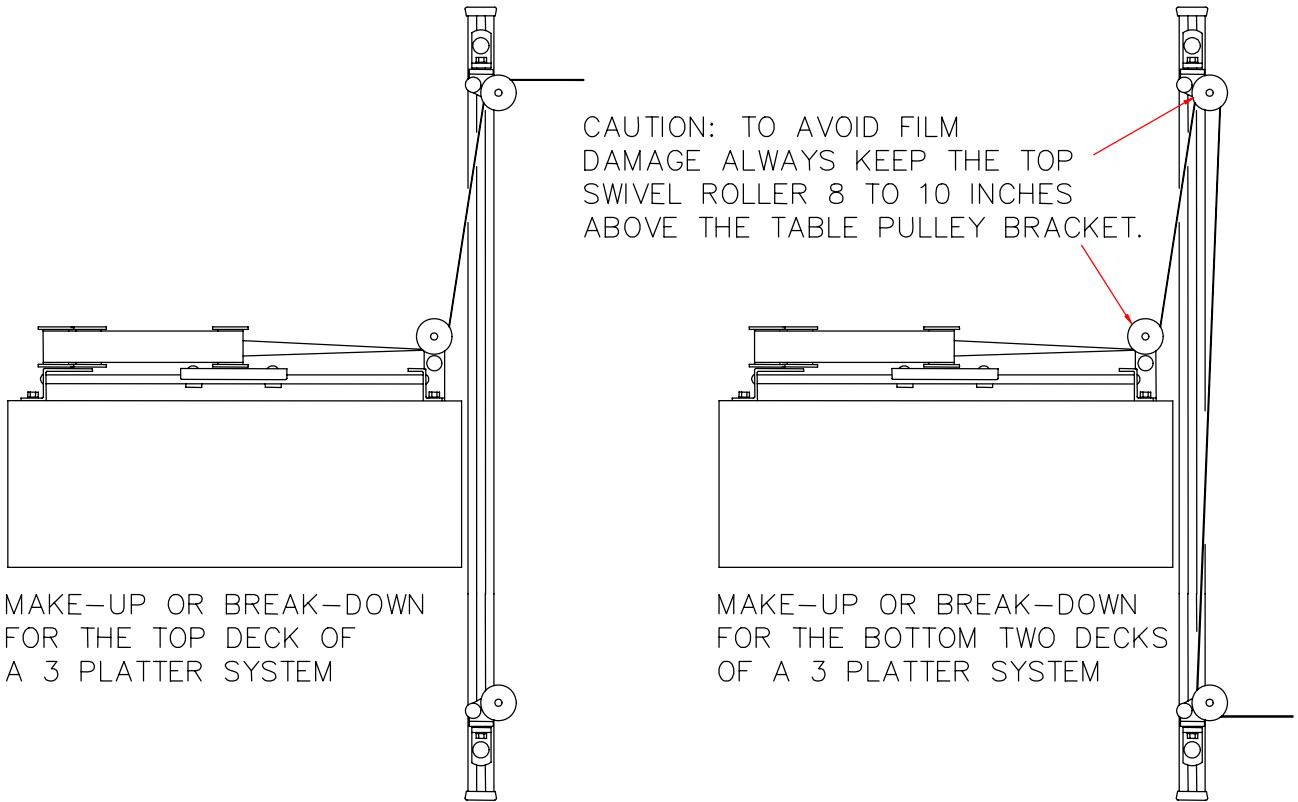
Trouble Shooting (continued)

2. If the film fails to transfer from the platter to the MAKE-UP TABLE during PROGRAM BREAK-DOWN:
  - a) Make sure the DRIVE MOTOR is DISENGAGED
  - b) Make sure the TABLE MODE SWITCH is in the REWIND position.
  - c) Check the MAKE-UP TABLE fuse.

## **MAINTENANCE**

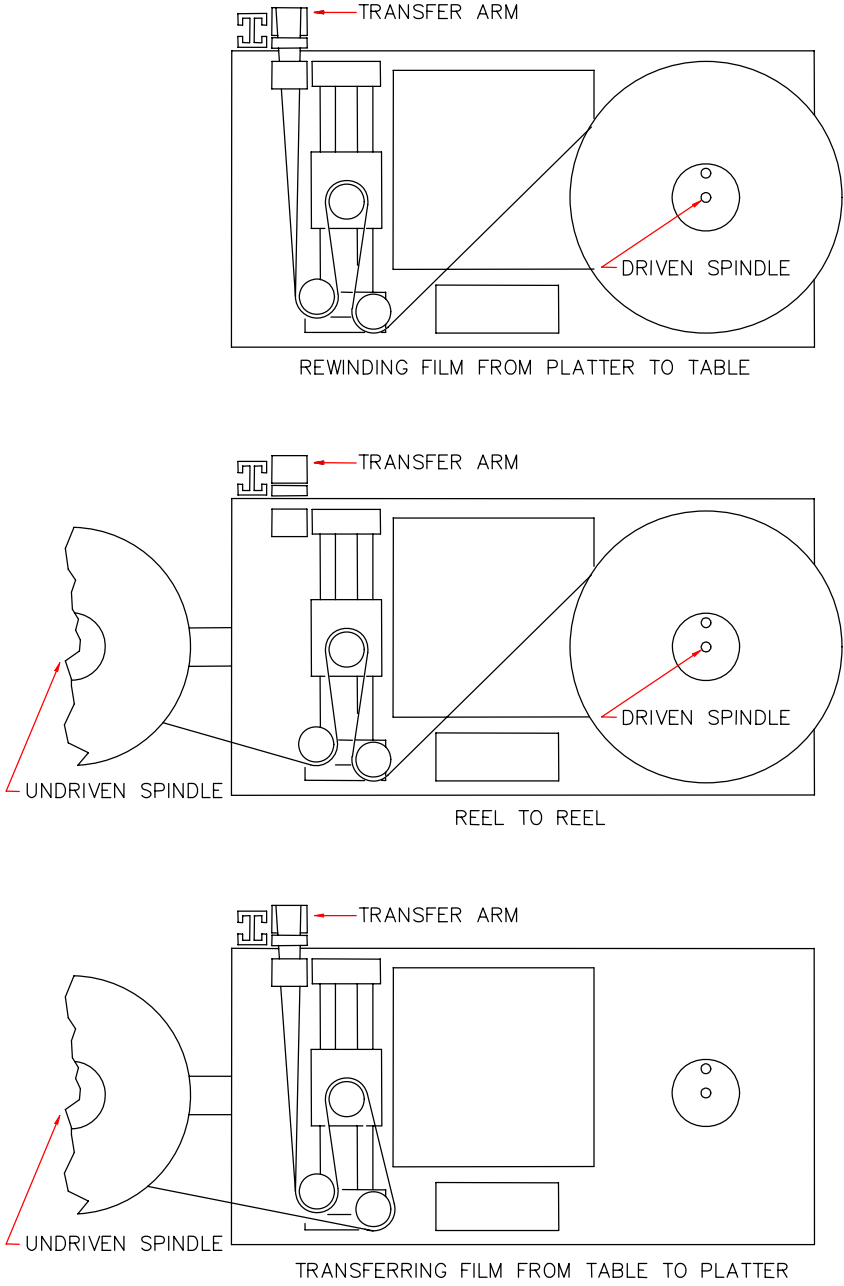
1. Keep the spindles, spools and pulleys clean. Prevention of oil and lint build-up is important. Alcohol is a suitable cleaning agent for this purpose.
2. Screws, bolts and nuts should be periodically checked for tightness.
3. Maintain all safety decals and replace as required (see page 3).
4. The framing light is fused independently from the table. The fuse is located on the rear wall of the light compartment. Use the appropriate fuse for 110V or 220V operation when replacing (see parts manual.) To replace the bulb, remove the four screws securing the light cover. Replace the bulb with the same type and reinstall the cover.

## TABLE THREADING DIAGRAMS

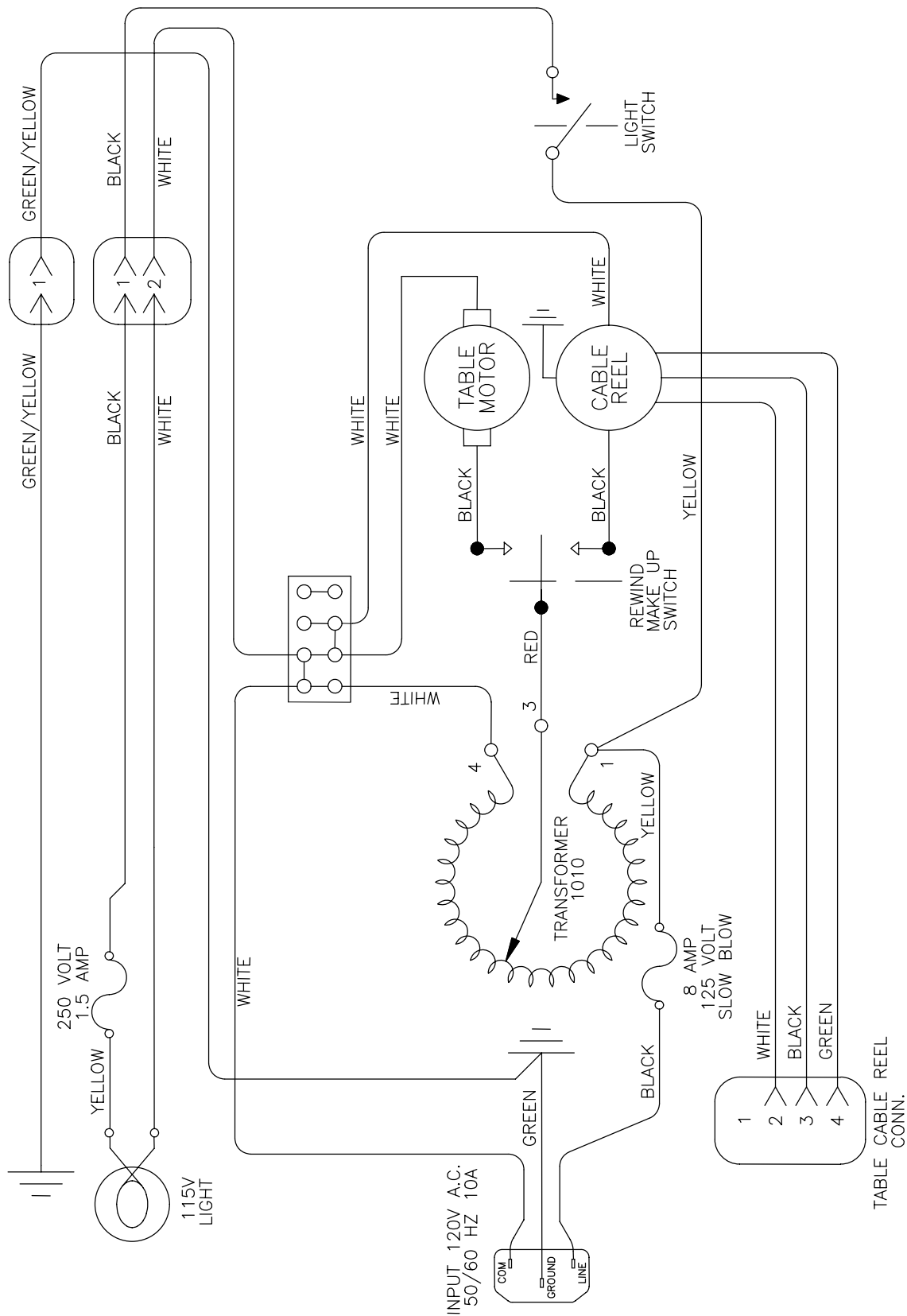


**Figure 8**

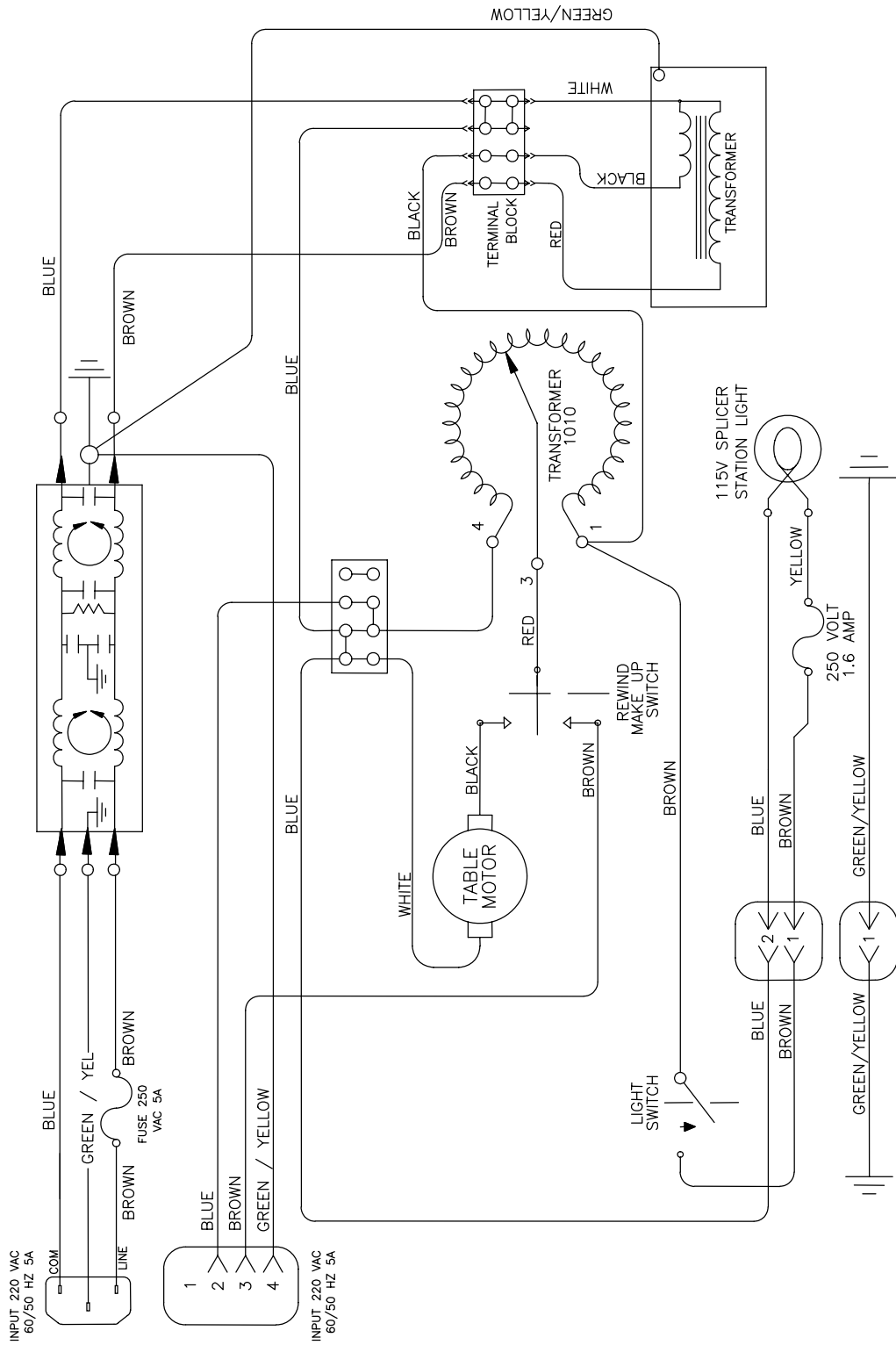
# TABLE THREADING DIAGRAMS



**Figure 9**



**110 VAC SCHEMATIC**



**CE (220 VAC) SCHEMATIC**