

SKIMERATOR® MODEL 3200F SPECIFICATIONS

Basic system includes shallow draft floating head skimmer box with screen, electric pump, reservoir with baffle assembly and weir box assembly, flow restrictor and all necessary hoses and fittings.

- Use in sumps where coolant level fluctuates more than the range of a fixed mount skimmer box. Electric pump mounts to floating head.

See Skimerator manual PIB 3241 for more information.

Note: Includes standard duty floats shown. Extreme duty floats are available. Order float option #6682-XD.

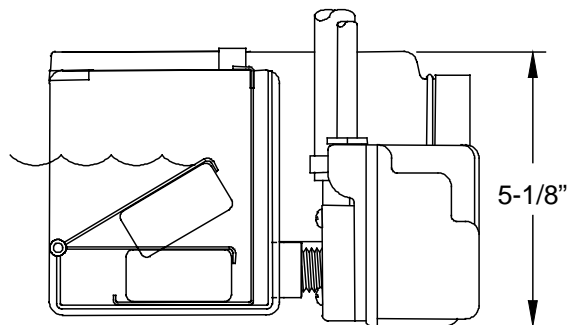
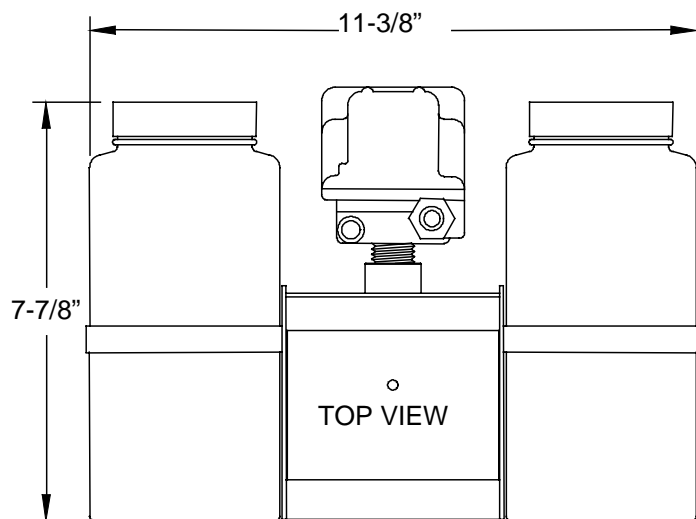
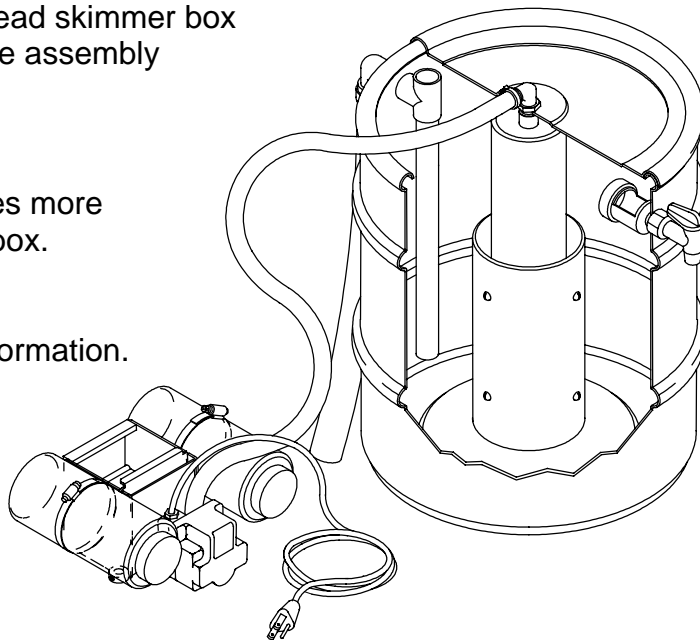

FLOATING HEAD DIMENSIONS

Pump specifications	Submersible, epoxy encapsulated motor, 115v, 1/125 HP. 10' cord.
Pump capacity	100 GPH (5' height) to 140 GPH (3' height) @3 PSI, 120 deg. max.
Reservoir	Translucent polyethylene, 15 gallon capacity, 16" dia x 21" high.
Warranty	12 months parts and labor

Manufactured in U.S.A. by:

Design & Manufacturing, Inc.

www.design-mfg.net
or phone 800/236-9496

