

SKIMERATOR® MODEL 3200C SPECIFICATIONS

Basic system includes shallow draft skimmer box with screen, skimmer box stand, 230V electric pump, reservoir with baffle assembly and weir box assembly, flow restrictor and all necessary hoses and fittings.

- **For use only in countries using 230v 50 Hz electrical power.**
- Use in sumps where the coolant level Varies no more than 3".
- Accommodates a coolant depth of 1-1/2" to 4-1/2" (with skimmer box on floor of sump) and 2-1/4" to 15-7/8" using the adjustable skimmer foot and post.

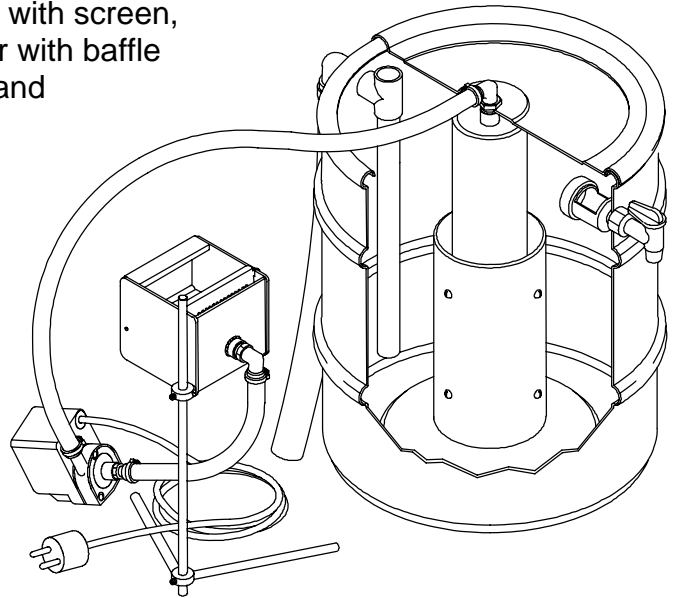

See basic installation sheet for more information.

SPECIFICATIONS

Pump specifications	Submersible, epoxy encapsulated motor, 230v 50 Hz CE, 1/40 HP 10' cord. Note: Pump is CE marked for use in Europe.
Pump capacity	290 GPH (1' height) @ 3.6 PSI, 8.3' max. lift
Reservoir	Translucent polyethylene, 15 gallon capacity, 16" dia x 21" high.
Warranty	12 months parts and labor

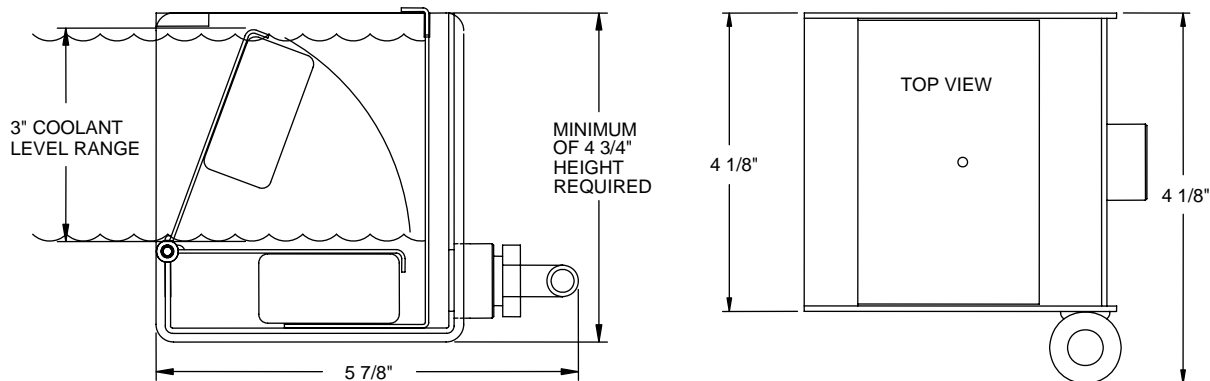

SHALLOW DRAFT SKIMMER BOX DIMENSIONS

Manufactured in U.S.A. by:
Design & Manufacturing, Inc.

www.design-mfg.net
or phone 800/236-9496

