

# SKIMERATOR® #5040 RESERVOIR STAND WITH WHEELS

- Elevates the Skimerator reservoir for efficient coolant return and aeration.
- Allows the reservoir with coolant to be moved between less frequently used machines or machines with smaller sumps.
- Rugged construction with a durable powder coat finish and heavy-duty castors.
- Storage shelf holds the skimmer box stand and accessories.
- Measures 16" X 16" X 16" tall. Weights 18 lbs.

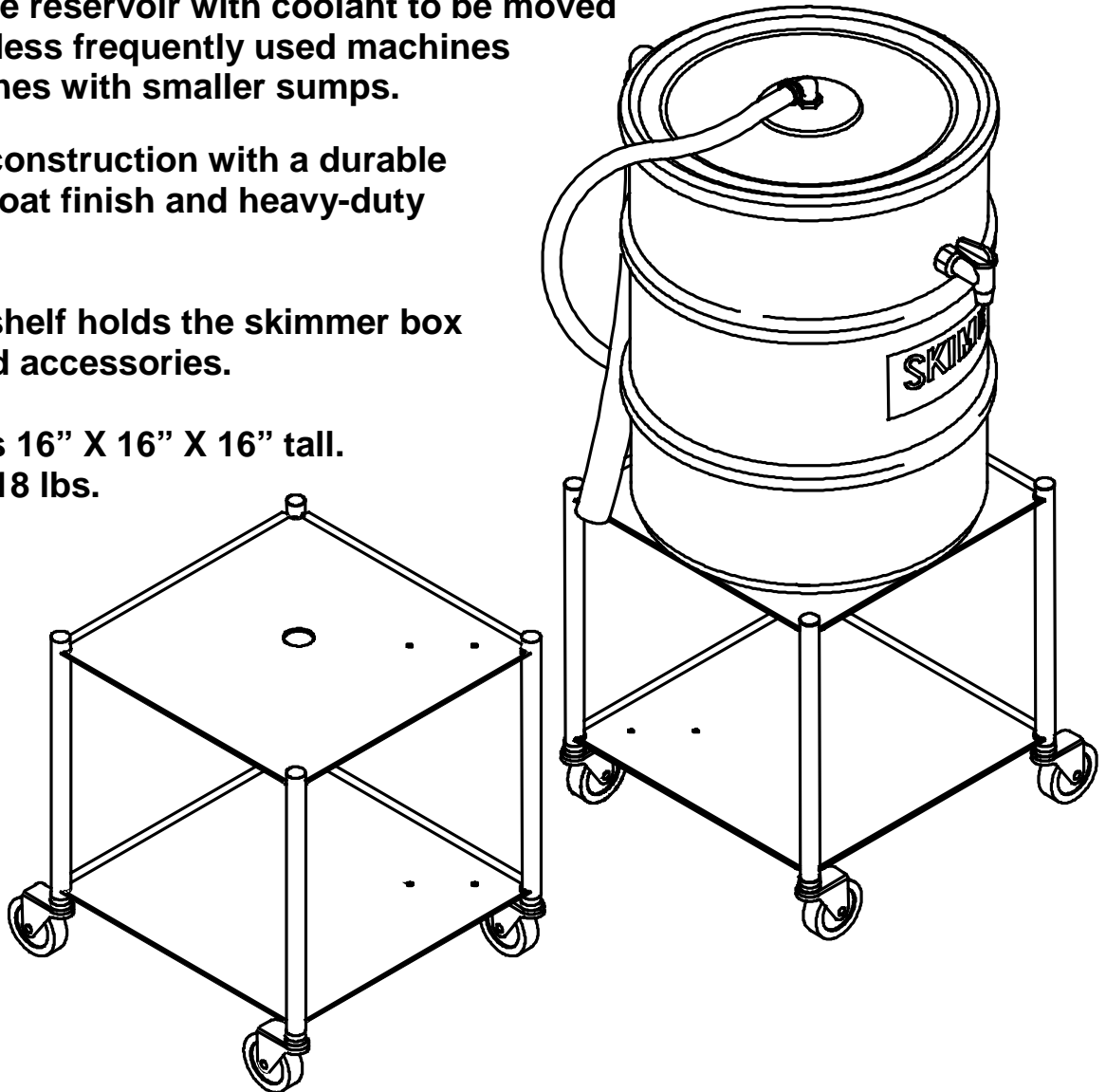

Manufactured in U.S.A. by:

**Design & Manufacturing, Inc.**

[www.design-mfg.net](http://www.design-mfg.net) or phone 800/236-9496

