

SKIMERATOR® MODEL 3200 SPECIFICATIONS

Basic system includes shallow draft skimmer box with screen, skimmer box stand, electric pump, reservoir with baffle assembly and weir box assembly, flow restrictor and all necessary hoses and fittings.

- Use in sumps where the coolant level varies no more than 3"
- Accommodates a coolant depth of 1-1/2" to 4-1/2" (with skimmer box on the floor of sump) and 2-1/4" to 15-7/8" using the adjustable skimmer foot and 12" post.

See Skimerator manual PIB 3241 for more information.

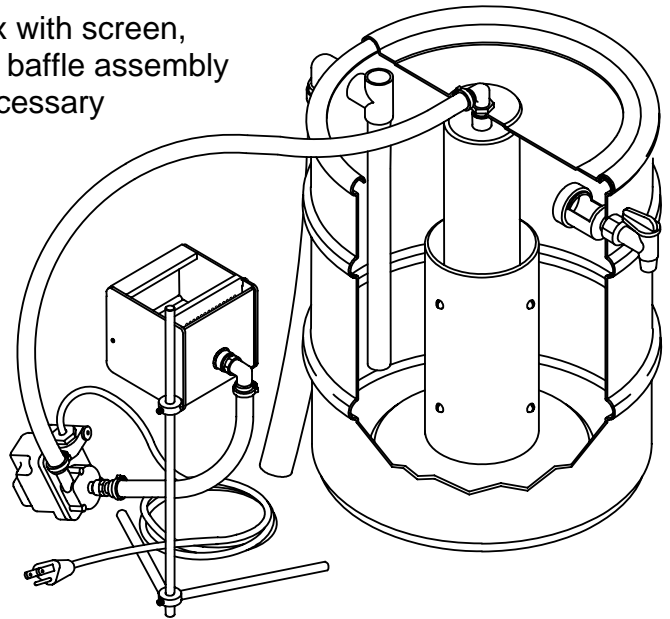

SPECIFICATIONS

Pump specifications	Submersible, epoxy encapsulated motor, 115v, 1/125 HP. 10' cord.
Pump capacity	100 GPH (5' height) to 140 GPH (3' height) @3 PSI, 120 deg. max.
Reservoir	Translucent polyethylene, 15 gallon capacity, 16" dia x 21" high.
Warranty	12 months parts and labor

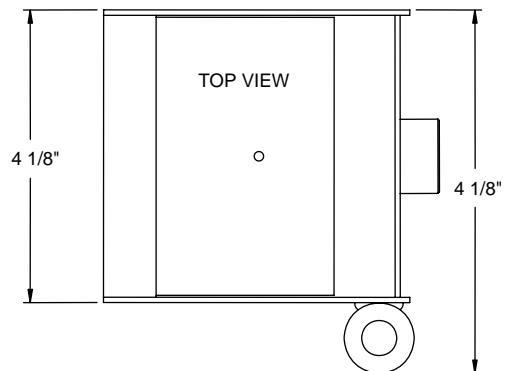
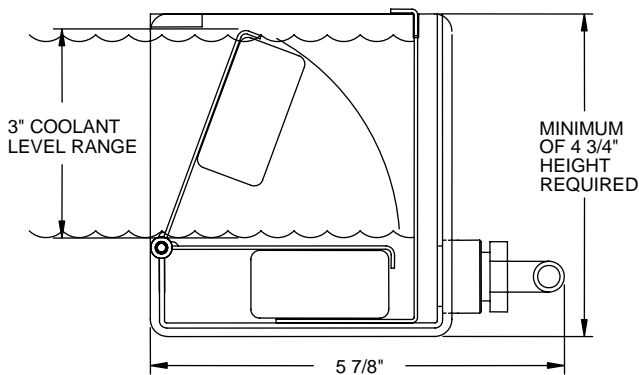

SHALLOW DRAFT SKIMMER BOX DIMENSIONS

Manufactured in U.S.A. by:

Design & Manufacturing, Inc.

www.design-mfg.net
or phone 800/236-9496

