

SKIMERATOR® MODEL 3200AP SPECIFICATIONS

Basic system includes shallow draft skimmer box with screen, skimmer box stand, air pump, reservoir with baffle assembly and weir box assembly, flow restrictor and all necessary hoses and fittings.

- Use in low temperature environments where an air pump is preferred to an electrical pump.
- Use in sumps with no room for a submersible electrical pump. Air pump is not submersible.
- Use in sumps where the coolant level varies no more than 3".
- Accommodates a coolant depth of 1-1/2" to 4-1/2" (with skimmer box on floor of sump) and 2-1/4" to 15-7/8" using the adjustable skimmer foot and post.

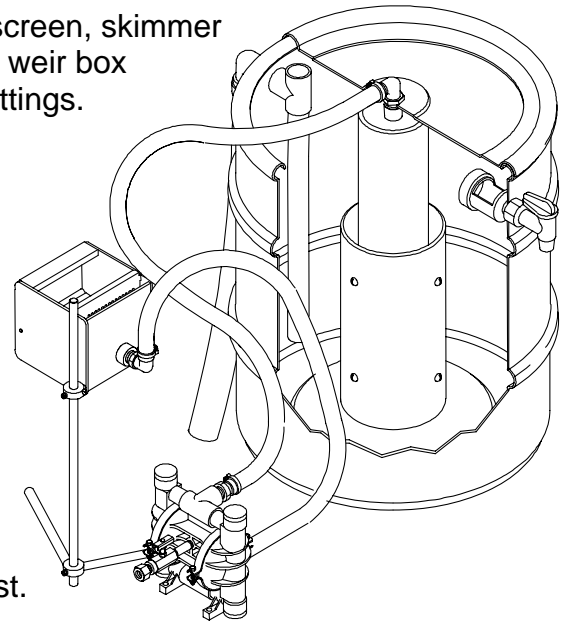

See Skimerator manual PIB 6540 for more information.

SPECIFICATIONS

Pump specifications	Polypropylene body w/ Wil-flex diaphragms, Self priming
Pump capacity	Max. flow rate 4.8 gpm.
Reservoir	Translucent polyethylene, 15 gallon capacity, 16" dia x 21" high.
Warranty	12 months parts and labor

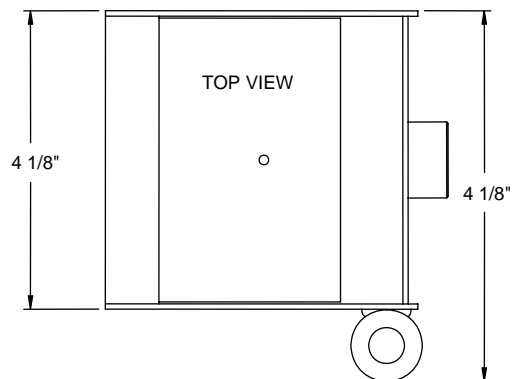
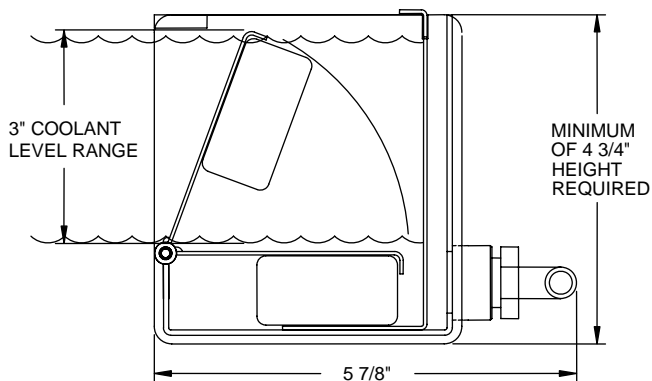

SHALLOW DRAFT SKIMMER BOX DIMENSIONS

Manufactured in U.S.A. by:

Design & Manufacturing, Inc.

www.design-mfg.net
or phone 800/236-9496

